

Multi Digital Controller

FX series

Temperature Controller	FX3S, FX3D, FX3FS, FX3T, FX3QR/FX3SR
Humidity Controller	FX3H, FX3DH
Refrigeration Controller	FX32J, FX32R, FX32K, FX32C, FX32PR, FX32EV, FX32S
Multi-Function Controller	FX32P, FX32F, FX32A, FX32A-351



FX Series

**Digital controller to fits perfectly
for your purpose,
Why don't you change to FX series?**



Easy Control & Best Price

FX series has easy settings and excellent transfer among each menu based on simple and convenient constitution, and it embeds a step-by-step access setup function (blind menu function), so that it can prevent the equipments from malfunction. Also, it can provide users with very reasonable price in contradistinction with cost in spite of a combination of network ability and control function.



±0.3°C Precise Temperature Control & High Reliability

The temperature sensors, such as NTC (-50~150°C), PT-100 (-200~800°C) and TC (0~1000°C) can measure temperature in wide range and provide users with very fine tolerances (0.1°C temperature resolution).



Free Voltage & Compact Design

There is no restriction to apply for AC100~240V and 50/60Hz. A simple and streamline shape provides users with visible convenience.



Error & Alarm Display

FX series can show the error information, such as failure and malfunction of the equipment as a simple message, so the supervisors can easily manage it.



Multi Digital Controller (MICOM) Function

FX series is an advanced multi function digital controller which embeds logic at the same level of MICOM according to models and various functions and oversteps bounds of simple temperature controllers.



RS485 & 4~20mA Analogue Output Function

Applying for RS485 communication method based on MODBUS RTU/ASCII Protocol, FX series helps users to construct convenient SCADA/HMI system which is possible for precise central concentrated monitoring with PLC, PC, and touch screen.



Compatibility for Various Sensors

According to request for each system, various types of sensors are applicable including a standard temperature sensor.



Now It's your turn
to experience DOTECH.

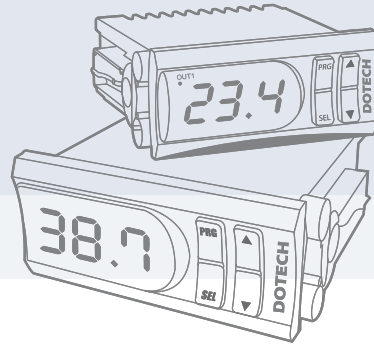



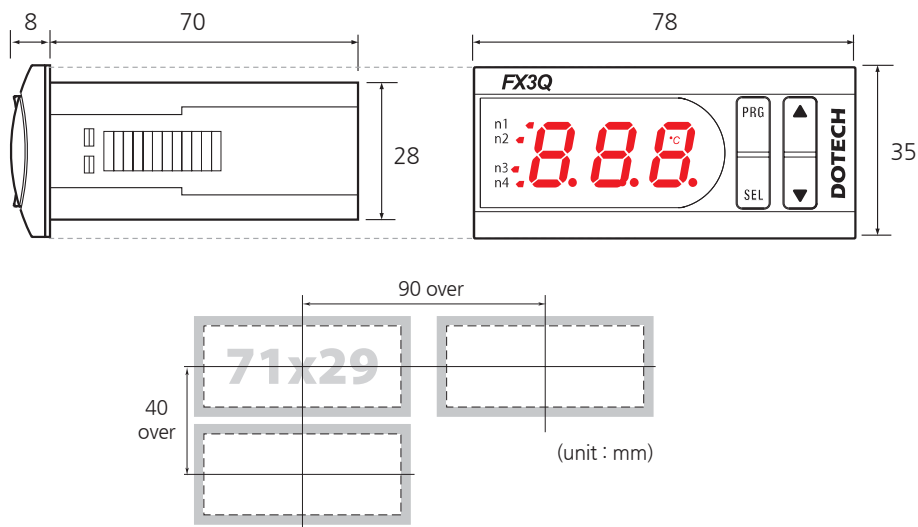

Standardized Dimensions (Panel Cut Size : 71 X 29mm)



Selection suitable model with the necessary functions

You can choose model with the functions that you want for your convenience.

Temperature	Humidity	Refrigeration	Multi
			
FX3S FX3T FX3D FX3QR FX3FS FX3SR	FX3H FX3DH	FX32J FX32K FX32R FX32C FX32PR FX32EV FX32S	FX32P FX32F FX32A FX32A-351

FX Series



03 Refrigeration Controller

FX32J

Showcase & Coldroom Controller **NTC** **RS485** **4~20mA** **Retrans**



Main-Function	Defrosting (auto/manual), fan control, efficient delay Room temperature sensor : 1EA, Defrost recovery sensor : 1EA. High (low) temp. alarm output, room temp. transmission output (4~20mA), RS485 communication (MODBUS)
Power Supply	AC100~240V, 50/60Hz, Max. 4VA, screw bolt terminals
Input/output	Relay output : 4 point, Temp. sensor input : 2 point
Sensor Spec	DPR-TH1 : NTC 5k, $\pm 0.3^{\circ}\text{C}$ at 25°C (-50~105 $^{\circ}\text{C}$)
Models	FX32J-00 : Basic model FX32J-R4 : Add on RS485 communication (MODBUS) FX32J-A1 : Add on 4~20mA transmission output FX32J-L1 : adopted printer for recoder FX32J-L2 : added data logger function FXP-60 : recording printer for FX32J-L1

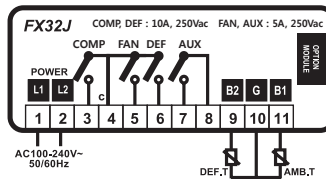

Comp: compressor(SOL) control output
Fan: fan control output
Def: defrosting control output
Al/aux: alarm/defrosting synchronization/heating control output

AMB.T : inside temperature sensor
DEF.T : sensor for return temperature after sensor for defrost recovery

FX32R

Showcase & Coldroom Controller **NTC** **RS485**



Main-Function	Defrosting (auto/manual), defrosting stop delay, evaporation fan control and delay, Air inlet/outlet sensor : 2EA, Defrost recovery sensor : 1EA, virtual temp. sensor computing, Door open alarm, emergency call, interlock, defrost activation, night operation, High (low) temp. alarm output, RS485 communication (MODBUS)
Power Supply	AC100~240V, 50/60Hz, Max. 8VA, connector (Molex)
Input/output	Relay output : 4 point, Digital input : 7 point, Temp. sensor input : 3 point
Models	FX32R-00 : Basic model FX32R-R4 : Add on RS485 communication (MODBUS)

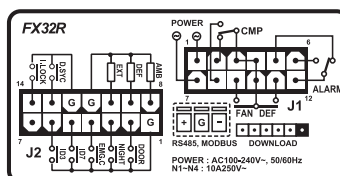

Comp: compressor(SOL) control output
Fan: fan control output
Def: defrosting control output
Al/aux: alarm/defrosting synchronization/heating control output

B1-AMB : inside temperature sensor
B2-DEF : sensor for return temperature after sensor for defrost recovery
B3-EXT : outlet temperature sensor

ID1-D.SYC: defrosting synchronization signal input
ID2-I.LOCK: interlock signal input
ID3-FAN.AL: fan alarm signal input
ID4-EMG.C: emergency(locking) switch signal input
ID5-NIGHT: NIGHT SETBACK signal input
ID6-DOOR: door open switch signal input
ID7-REMOTE : remote operation stop signal input

Multi Digital Controller FX Series

FX32K

Defrost factor Controller **Defrost** **4~20mA** **RS485**



Main-Function	Efficient defrosting in geothermy heat pump system Defrosting execution by measuring of ambient humidity and temperature
Power Supply	AC100~240V, 50/60Hz, Max. 4VA, screw bolt terminals
Input/output	Relay output : 2 point, Digital input : 1 point, Temp. sensor input : 2(3) point, humidity sensor input : 1 point
Models	FX32K-00 : Basic model FX32K-30 : Add on humidity sensor FX32K-30-R4 : Add on RS485 communication (MODBUS)

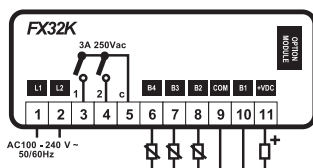

B1 : Ambient humidity 4~20mA input
B2 : Ambient temperature sensor input
B3 : Refrigerant suction temperature sensor input
ID1 : Interlock signal
Def : Defrost ON/OFF output
Al/aux : Alarm output

FX32C

Compressor Protector **NTC** **RS485**



Main-Function	Total control and detection (protection) for freezers Function of start, restart, pump down, alarm delay timer, discharge gas detection (high & low Temp.), Individual alarm message (OC, HP, LP, OP, INT, etc.), Liquid injection (discharge gas detection), communication (RS485 MODBUS)
Power Supply	AC100~240V, 50/60Hz, Max. 8VA, connector (Molex).
Input/output	Relay output : 4 point, Digital input : 7 point temp. sensor input : 3 point
Models	FX32C-00 : Basic model FX32C-30 : Add on discharge gas detection and control FX32C-40 : Add on discharge gas and room temp. control -00 : Without Communication function -R4 : Add on RS485 communication (MODBUS RTU/ASCII MODE)

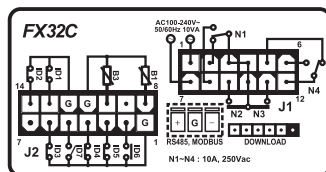

Comp : COMP RUN/STOP
Sol : SOL V/V ON/STOP
Inj : INJECTION SOL
Al/aux : Alarm
B1 : AMBIENT TEMP
B2 : SPARE
B3 : DISCHARGE GAS TEMP

ID1 : OCR
ID2 : INT
ID3 : HPS
ID4 : OPS / PMR
ID5 : LPS
ID6 : INTERLOCK
ID7 : RUN/STOP

FX32PR

Digital Low/High Pressure Controller **4~20mA** **RS485** **Retrans**



Main-Function	uniform step control, operation with intelligent shift high/low alarm output, sensor correction, sensor error detection, transmission output, communication (RS485 MODBUS)
Power Supply	AC100~240V, 50/60Hz, Max. 4VA
Input/output	One sensor input of 4~20mA (embedded sensor loop power), Four relays (three relays for step control, one relay for alarm output)
Sensor Spec	DP506.930A : -1~9 bar, 4~20mA, 2wire (For refrigeration application) DP506.933A : 0 ~ 30 bar, 4~20mA, 2wire (For refrigeration application) DP510 : 0 ~ 16 bar, 4~20mA, 2wire (exclusive pressure sensor for air compressor)
Models	FX32PR-00 : Basic model FX32PR-R4 : Add on RS485 communication (MODBUS) FX32PR-A1 : Add on 4~20mA transmission output

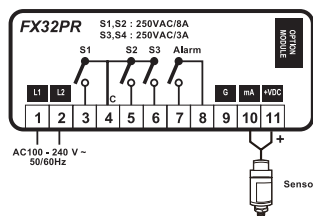

RS-485 COMM. OPTION MODULE
1 TRX ⊕
2 TRX ⊖
3 SG

RS-332 COMM. OPTION MODULE
1 RXD
2 TXD
3 GND

4~20mA Output OPTION MODULE
1 4~20mA ⊕
2 4~20mA ⊖
3 SG

FX Series

FX32EV

Electronic Expansion Valve controller

Pt1000

4~20mA

RS485

Retrans



Main-Function	PID degree of superheat control through defense and safety compensation, degree of superheat control for various refrigerant, PWM(opening ratios control), remote operation, transmission output, RS485 communication (MODBUS)
Power Supply	AC100~240V, 50/60Hz, Max. 4VA, screw bolt terminals
Input/output	SSR output 1-point (expansion valve on/off), relay output 1-point(alarm port), temperature sensor 1-point, 4~20mA pressure sensor input 1-point (embedded sensor loop power)
Sensor Spec	Temp. sensor (DPR-PT1K-P6D5OL, -100~100°C) Pressure sensor (-1~9 bar or 0~30 bar)
Models	FX32EV-00 : Basic model FX32EV-R4 : Add on RS485 communication (MODBUS) FX32EV-A1 : use for 4~20mA type Electronic Expansion Valve or pressure transmission output function FX32EV-R2 : Add on RS232 communication

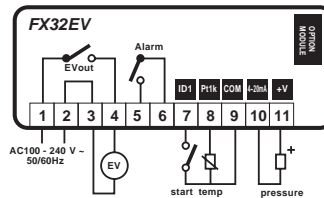

FX32S series

Showcase & Coldroom Controller

NTC

RS485



Main-Function	Defrosting (auto/manual), defrosting stop delay, two air inlet and outlet sensors, one sensor for defrost recovery, High(low) alarm output, RS485 communication (MODBUS), indicator(FxiView) connection
Power Supply	AC100~240V, 50/60Hz, Max. 8VA, connector (Molex)
Input/output	relay output max 4-point, temperature sensor input max 3 point
Sensor Spec	DPR-TH1 : NTC 5k, ±0.3°C at 25°C (-50~105°C)

Models	FX32S	FX32SD	FX32SA	FX32SF	FX32SB	FX32SR
Compressor	16A	16A	16A	16A	16A	8A
Defrost	-	8A	-	-	8A	8A
Eva Fans	-	-	-	8A	8A	8A
Aux.output	-	-	8A	-	-	8A
Room Temp.	●	●	●	●	●	●
Defrost Temp.	-	●	●	●	●	●
Digital Input (Probe3)	-	●	●	●	●	●
RTC	-	-	-	-	-	-
RS485	○	○	○	○	○	○

● : Basic
○ : Option

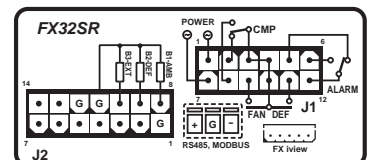
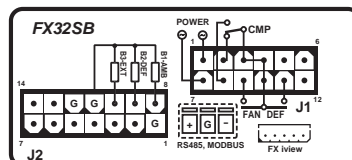
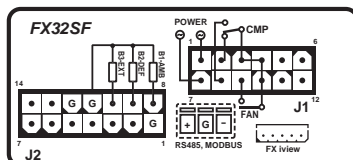
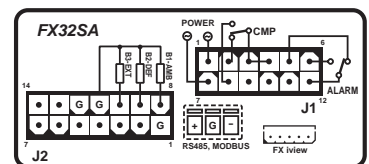
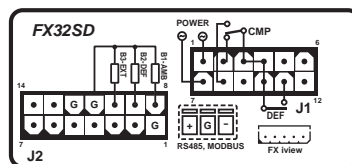
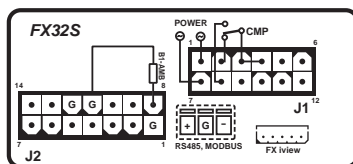

FX Series Specification

Hardware Comparison per Each Model

Section	Rated Power	Power Consumption	Sensor Input	Analogue Input	Analogue output (option)	Digital Input	Digital output	Communication Port(option)	Field of application	
FX3S (NTC)	AC100-240V~50/60Hz	Max. 4VA	NTC 1P	-	-	-	16A 250Vac 1P	-	wine seller, flower refrigerator, refrigerator, deep freezer etc. places where need to be controlled temperature, humidity and pressure	
FX3D (NTC,4~20mA)			NTC 1P	4~20mA 1P	4~20mA 1P	-	10A 250Vac 2P	RS485		
FX3FS (NTC)			NTC 2P	-	-	-	16A 250Vac 1P	-		
FX3T (Thermo-Couple)			TC(K)1P	-	4~20mA 1P	-	10A 250Vac 3P	RS485		
FX3QR (RTD)			Pt100 1P	-	4~20mA 1P	-	5A 250Vac 2P 10A 250Vac 2P	RS485		
FX3SR (RTD)			Pt100 1P	-	4~20mA 1P	-	16A 250Vac 1P	RS485	for precision	
FX3H (Humidity)			-	1~3.6V 1P	-	-	16A 250Vac 1P	-	Humidity Control	
FX3DH (Temp. & Humidity)			NTC 1P	1~3.6V 1P	4~20mA 1P	-	8(2)A 250Vac 2P	RS485		
FX32J (Showcase & Coldroom)			Max. 4VA	NTC 2P	-	4~20mA 1P	-	5A 250Vac 2P 10A 250Vac 2P	RS485	showcase, low temperature warehouse, deep freezer
FX32R (Showcase & Coldroom)			Max. 8VA	NTC 3P	-	-	7P	10A 250Vac 4P	RS485	
FX32K (Defrost)			Max. 4VA	NTC 2(3)P Humidity 1P	-	-	1P	3A 250Vac 2P	RS485	Heat pump
FX32C (Compector)			Max. 8VA	NTC 3P	-	-	7P	10A 250Vac 4P	RS485	Refrigeration
FX32PR -			Max. 4VA	-	4~20mA 1P	4~20mA 1P	-	8A 250Vac 2P 3A 250Vac 2P	RS485	High/Low Pressure Control
FX32EV -			Max. 4VA	Pt1000 1P	4~20mA 1P	4~20mA 1P	1P	SSR 1P	RS485	Electronic Expansion Valve
FX32S seires -			Max. 8VA	NTC 2(3)P	-	-	2P	5~16A 250Vac 4P	RS485	Showcase
FX32P (Pressure Switch)				-	4~20mA 1P	4~20mA 1P	-	10A 250Vac 2P 5A 250Vac 2P	RS485	pressure control device
FX32F (Fan-coil Unit)		NTC 2P	-	-	-	2A 250Vac 3P	RS845	Fan coil		
FX32A (Air-Compressor)		NTC 1P	4~20mA 1P	4~20mA 1P	2P	10A 250Vac 2P	RS485	Air Compressor		
FX32A-351 (Air-Compressor)		NTC 2P	4~20mA 1P	4~20mA 1P	2P	3A 250Vac 2P	RS485			