



FDM06-I Venturi Thermal Mass Flow Meter



| Features |

- Precise Measurement : Utilizes a unique Venturi tube structure
- 2" LCD Screen : Easily configurable with buttons
- Display Features : Shows instant and cumulative measurements; screen rotates 90 degrees for easy viewing
- Multiple Pipe Diameters Available : (DN15 / DN25 / DN40 / DN50) for easy installation
- Accuracy : $\pm 2.0\%$ F.S., pipeline withstand pressure of 16 bar
- Multiple Outputs: Analog output / Relay / RS-485

| Applications |

Compressed Air Systems / Pneumatic Systems / Dryers / Air Consumption Monitoring / Pipeline Leak Monitoring

| Specification |

Input

Sensor type	Hot-wire sensor
Turndown ratio	75 : 1
Measuring range	DN15 : 65 Nm ³ /h
	DN25 : 160 Nm ³ /h
	DN40 : 350 Nm ³ /h
	DN50 : 500 Nm ³ /h

*The measurement range is defined at the standard condition(1013 mbar, 20°C).

Output

Output signal	4 ... 20 mA / 0 ... 10 V / Relay
Signal connection	M12 3-wire
Warm-up time	60 sec
Response time	t ₉₀ ≤ 6 sec
Load resistance	Current output : ≤ 500 Ω
	Voltage output : ≥ 10 KΩ

Communication

Communication methods & protocol	RS-485 Modbus RTU
RS-485 baud rate	9600 · 19200 · 38400 · 57600 · 115200 bps

Accuracy (at 25°C)

Accuracy	±2% F.S.
Temp. influence	0.2% / °C
Repeatability	0.5%

Environmental

Medium	Non-corrosive gas
Operating Temp. & Humid.	0 ... 50°C / 20 ... 90%RH(Non-condensing)
Storage Temp.	-20 ... +60°C
Operating pressure	16 bar

Electrical

Power supply	DC 24 V ± 10%
Current consumption	24 V : 110 mA
Relay capacity	Max current : 6 A
	Max voltage : DC 24 V (DC 36 V Max)
Electrical connection	M12 8P connector

Installation

Pipe connection	G thread
Pipe size	DN15 (1/2") · DN25 (1") · DN40 (1-1/2") · DN50 (2")

Display

Display readout	0 ... 99999999 (Cumulative flow : 8-digit)
	0 ... 99999 (Instantaneous flow : 5-digit)
Decimal point	Button
Sampling time	1 cycle/sec
Flow unit	mL · L · m ³ · gal · ft ³ · inch ³ · UK gal
Time unit	/min · /hr
Response time adjustment range	0.5 ... 300 sec

Certification

Certification	CE
---------------	----

Protection

IP rating	IP65
Electrical protection	■ Reverse polarity ■ Over-voltag

Material

Pipe	Aluminum alloy
Housing	Aluminum alloy
Weight	DN15 (1/2") : 0.9 Kg · DN25 (1") : 0.8 Kg
	DN40 (1-1/2") : 1.1 Kg · DN50 (2") : 1.3 Kg

| Diagram |

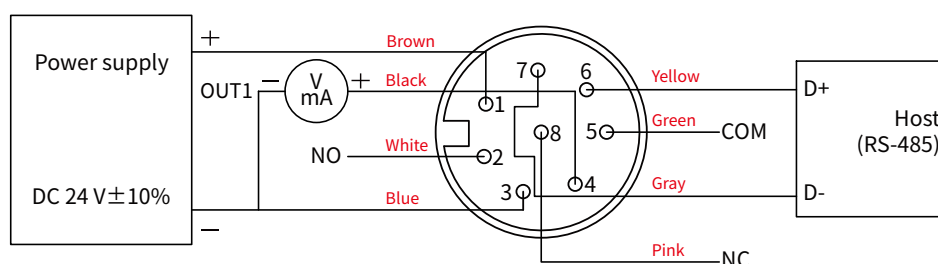

*Please make sure the product and the device which connect with RS-485 are on common ground, avoid damaged product.

| Measurement Principle |

■ Venturi tube

The Venturi tube is a flow measurement device designed based on the Venturi effect and is often used in conjunction with differential pressure transmitters. When flow passes through the narrow center of the Venturi tube, its velocity increases while the pressure decreases; this phenomenon is known as the Venturi effect. According to Bernoulli's principle and the continuity equation, the pressure difference between the inlet section and the narrow center is proportional to the square of the fluid velocity, and the product of the velocity and the cross-sectional area at different points remains constant. Therefore, by measuring the differential pressure, the velocity at the narrow center can be calculated. The Venturi tube has significant advantages in flow measurement, including high accuracy and low pressure loss, allowing for precise measurement while minimizing energy loss. It is suitable for various fluids, including gases, liquids, and steam. Its robust structure, with no moving parts, requires minimal maintenance, reducing operational costs.

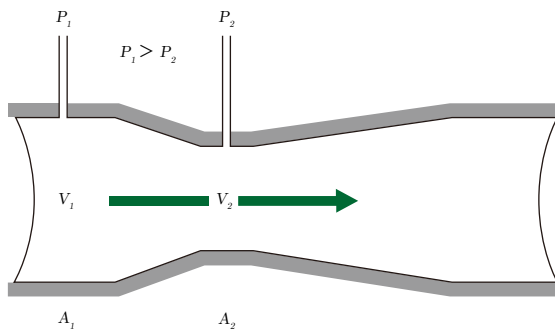

■ Formula

$$P_1 - P_2 = \frac{\rho}{2} (V_2^2 - V_1^2)$$

$$A_1 V_1 = A_2 V_2$$

P_1 : Pressure 1

P_2 : Pressure 2

ρ : Density

V_1 : Velocity 1

V_2 : Velocity 2

A_1 : Cross-sectional area 1

A_2 : Cross-sectional area 2

■ Hot-wire type differential pressure

Hot-wire type differential pressure measurement technology calculates the pressure difference by measuring the air flow rate. When there is a pressure difference between two measurement points, air flows from the high-pressure side to the low-pressure side through a channel inside the transmitter. The channel contains a heating element and two temperature sensors. By comparing the heating and temperature changes, the air flow rate can be precisely measured, which in turn allows the calculation of the pressure difference. This technology can detect extremely low air flow rates, making it possible to precisely measure small pressure differences. Additionally, hot-wire type measurement technology has the characteristic of low zero-point drift, meaning the transmitter can maintain a stable initial zero point even after prolonged use, ensuring measurement precision and reliability.

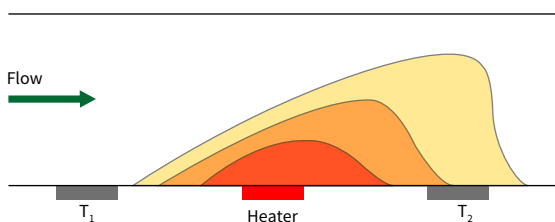

■ Formula

$$P = A + B \cdot V^n$$

P : Heating power

A : Power loss with no flow

V : Velocity

B : Fluid velocity

n : Velocity exponent

Dimension | Unit : mm

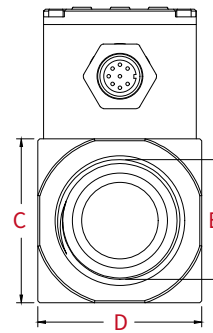
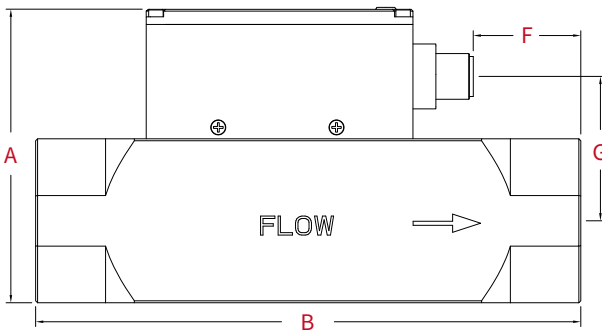
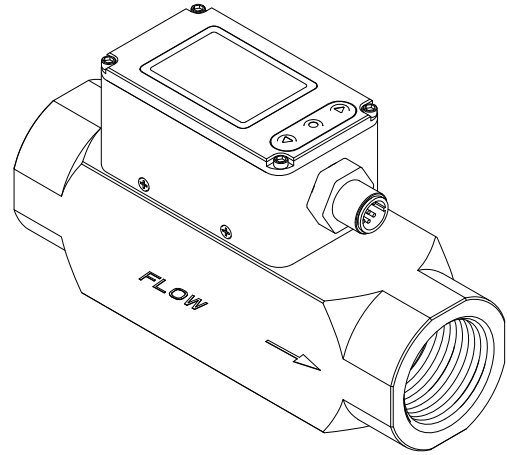
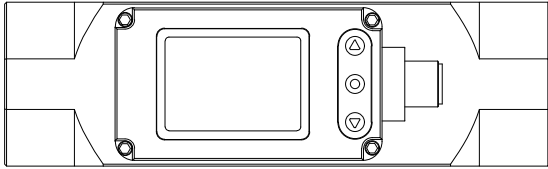

	DN15 (1/2")	DN25 (1")	DN40 (1-1/2")	DN50 (2")
A	75 mm	77 mm	91.5 mm	102 mm
B	143 mm	143 mm	170 mm	200 mm
C	43 mm	43 mm	57.5 mm	68 mm
D	43 mm	43 mm	58 mm	68 mm
E	DN15 (1/2")	DN25 (1")	DN40 (1 1/2")	DN50 (2")
F	28.2 mm	28.2 mm	59.2 mm	84.2 mm
G	35.8 mm	37.8 mm	44.3 mm	50.3 mm

| Ordering Guide |

FDM06-I	—	Diameter & Range D25	—	Connection G	—	Output 2	—	Option W
		D15 : DN15 (1/2") , 65 m ³ /h D25 : DN25 (1") , 160 m ³ /h D40 : DN40 (1-1/2") , 350 m ³ /h D50 : DN50 (2") , 500 m ³ /h		G : G thread		2 : 4 ... 20 mA+RS-485+Relay 3 : 0 ... 10 V+RS-485+Relay		W : Other request

| Calibration System |

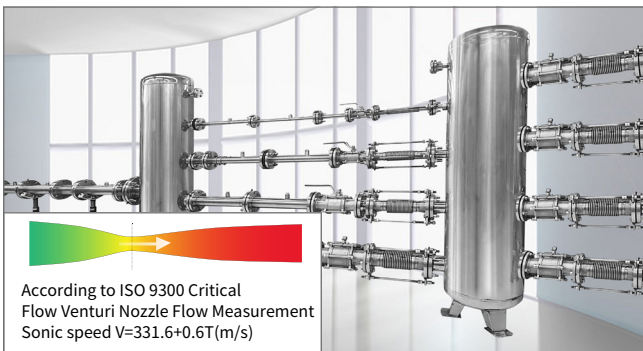

Air volume standard calibration system

Air volume : 0.5 m³/h ... 1000 m³/h

Referring to ISO 9300 "Flow Measurement of Critical Flow Venturi Nozzles", this device is a standard flow device combination consisting of multiple venturi nozzles according to the maximum and minimum flow ranges that need to be calibrated.

| Additional Option Test Report | For more detailed information please contact us.

■ ILAC / TAF

YUDEN-TECH CO.,LTD. Calibration Laboratory - (ILAC / TAF) Test report.

(TAF accreditation : 3032, complying with ISO / IEC 17025) TAF has mutual recognition arrangement with ILAC MRA

Project	Measurand level or range
Air velocity transmitter	0.2 m/s ... 60 m/s

■ ISO 9001

Project	Measurand level or range
Air velocity / Air volume	Air velocity : ≤ 120 m/s
	Air volume : 0.5 m ³ /h ... 1000 m ³ /h