



RFL100 Wireless Data Logger for continuous monitoring systems



Features

- Industry-leading measurement precision
- Interchangeable high-accuracy probes for T, RH, and CO₂
- 30-day memory buffer
- Typical battery life of 18 months in RH and T measurement
- Uses standard alkaline batteries
- Probe calibrations are traceable to SI units through national metrology institutes or accredited calibration laboratories
- Cost-effective alternative to chart recorders

RFL100 Data Logger uses Vaisala's proprietary VaiNet wireless technology. It can be used to monitor temperature (T), relative humidity (RH), and carbon dioxide level (CO₂) in a wide range of environments. Suitable applications include warehouses, production areas, cleanrooms, laboratories, incubators, fridges, cold storage areas, and freezers down to -196 °C (approx. -320 °F).

VaiNet wireless

RFL100 connects wirelessly to Vaisala viewLinc Monitoring System, which provides real-time trends, alarms, and historical reporting. VaiNet wireless technology provides a robust wireless signal that is extremely reliable over long distances and in complex, obstructed conditions. This wireless technology allows the data logger's signal to travel over 100 m (approx. 330 ft) indoors without the aid of signal amplifiers or repeaters. Wireless communications are encrypted to ensure data integrity and security.

Measurements are updated and stored every 60 seconds, and sent from the data logger every 4 minutes. In case of temporary network disruptions, the data logger can record up to 30 days of measurements that are automatically transmitted to the viewLinc Enterprise Server software when communications are restored. Recorded data can also be downloaded directly from RFL100 through the USB port.

Versatility and convenience

RFL100 requires no startup configuration, and the included mounting bracket supports several installation methods. Detailed custom display shows the latest measurement results, alarm and battery status, and signal strength of the current access point connection. The housing is classified IP54 to protect the device from dust and cleaning.

RFL100 is powered by two standard AA size 1.5 V batteries (LR6 alkaline or FR6 lithium) for 18 months of operation at approximately 20 °C (68 °F) in RH and T measurement. When fresh batteries are inserted during yearly calibration, battery replacement between calibrations is not needed. External power is required for CO₂ measurement, with the batteries serving as backup in case the external power becomes unavailable.



Interchangeable probes

The probes are detachable and easy to switch out for calibration. viewLinc Enterprise Server detects the changed probe information automatically and maintains accurate and complete historical records.

RH and T probes use Vaisala HUMICAP® humidity sensors and platinum temperature sensors (Pt100 and Pt1000 type) for superior stability. Probes can be integrated with the RFL100 housing or connected using a cable.

CO₂ measurement is provided by the GMP251 probe that uses Vaisala's patented, latest-generation CARBOCAP® technology with exceptional stability. The probe automatically compensates the CO₂ measurement according to ambient temperature.

Probe options

Probe	Description ¹⁾	Installation notes
<p>HMP110, HMP110T, and HMP110REF</p> 	<p>Humidity and temperature probe for measurement in demanding conditions. Robust stainless steel construction. Temperature-only version HMP110T available.</p> <p>Plastic grid filter provides the fastest response time. For added protection, select the membrane filter, the PTFE filter, or the stainless steel sintered filter.</p> <p>Measurement temperature range $-40 \dots +80 \text{ }^{\circ}\text{C}$ ($-40 \dots +176 \text{ }^{\circ}\text{F}$).</p>	<p>Suitable for measurement inside chambers, incubators, fridges, and freezers.</p> <p>Versatile mounting options using accessories.</p> <p>Must be connected to RFL100 using a cable.</p> <p>A constant output probe version HMP110REF is also available for validating installations. The constant output version does not measure – instead, it outputs unchanging humidity and temperature values.</p>
<p>HMP115 and HMP115T</p> 	<p>Humidity and temperature probe for general purpose measurement. Temperature-only version HMP115T available.</p> <p>Plastic grid filter provides the fastest response time. For added protection, select the membrane filter or the PTFE filter.</p> <p>Measurement temperature range $-40 \dots +60 \text{ }^{\circ}\text{C}$ ($-40 \dots +140 \text{ }^{\circ}\text{F}$).</p>	<p>Ideal choice for ambient measurement.</p> <p>Can be integrated with the RFL100 housing or connected using a cable.</p>
<p>TMP115</p> 	<p>Temperature probe for measurement in a wide range of conditions.</p> <p>Available as 50 cm (1 ft 7.7 in) and 3 m (9.8 ft) long versions. Length includes the probe body and sensor tip.</p> <p>Measurement temperature range $-196 \dots +90 \text{ }^{\circ}\text{C}$ ($-320 \dots +194 \text{ }^{\circ}\text{F}$).</p> <p>Operating temperature range of the probe body is $-40 \dots +60 \text{ }^{\circ}\text{C}$ ($-40 \dots +140 \text{ }^{\circ}\text{F}$).</p>	<p>Suitable for measurement inside chambers, fridges, and freezers.</p> <p>Can be integrated with the RFL100 housing or connected using a cable.</p> <p>Sensor tip withstands immersion in glycol and liquid nitrogen.</p> <p>Use the thermal dampener block accessory (item code 236310SP) to add thermal mass to the sensor tip.</p>
<p>GMP251</p> 	<p>Carbon dioxide probe for %-level measurements. Designed for use in demanding applications such as life science incubators.</p> <p>Measurement temperature range $-40 \dots +60 \text{ }^{\circ}\text{C}$ ($-40 \dots +140 \text{ }^{\circ}\text{F}$).</p> <p>When ordered with the RFL100 data logger, the probe is delivered with a mounting kit that includes a probe holder designed for use with GMP251 and the other supported probes. The kit also includes a magnetic holder for the Probe Splitter M8/M12 accessory.</p>	<p>Must be connected using the Probe Splitter M8/M12 accessory. Any one of the other supported probes can be connected at the same time in the M8 connector of the probe splitter.</p> <p>Requires use of external power supply due to power consumption. Data logger batteries provide a backup in case the external power is not available.</p> <p>Logged temperature data is limited to range $-40 \dots +60 \text{ }^{\circ}\text{C}$ ($-40 \dots +140 \text{ }^{\circ}\text{F}$) when GMP251 is connected.</p>

¹⁾ See probe datasheets for detailed probe specifications.

Accessories

Accessories

Accessory ¹⁾	Item code
Probe cable for RFL100, 1.5 m	CBL210555-1M5SP
Probe cable for RFL100, 3 m	CBL210555-3MSP
Probe cable for RFL100, 10 m	CBL210555-10MSP
Flat cable for RFL100, 3 m	CBL210647SP
Probe holder (5 pcs) for Ø 12 mm probes	ASM213382SP
CO ₂ probe mounting kit	ASM214253SP
Probe splitter M8 (for connecting two T probes)	CBL210834SP
Probe splitter M8/M12 (for connecting a CO ₂ probe)	CBL211050SP
1 m high-temperature cable M12 (for CO ₂ probe) ²⁾	271038SP
1 m high-temperature cable M8 (for RH/T probe in CO ₂ applications) ²⁾	271039SP
Universal power supply (100–240 V AC / 5 V DC) with micro-USB connector	ASM214178SP

1) See probe datasheets for probe-specific accessories.

2) High-temperature cables are extensions for the probe splitter M8/M12 in CO₂ applications. They tolerate –20 ... +180 °C (–4 ... +356 °F) temperatures and can remain inside an incubator during a typical heat sterilization cycle. Due to heat conduction, leave half of the cable in ambient temperature when installed.

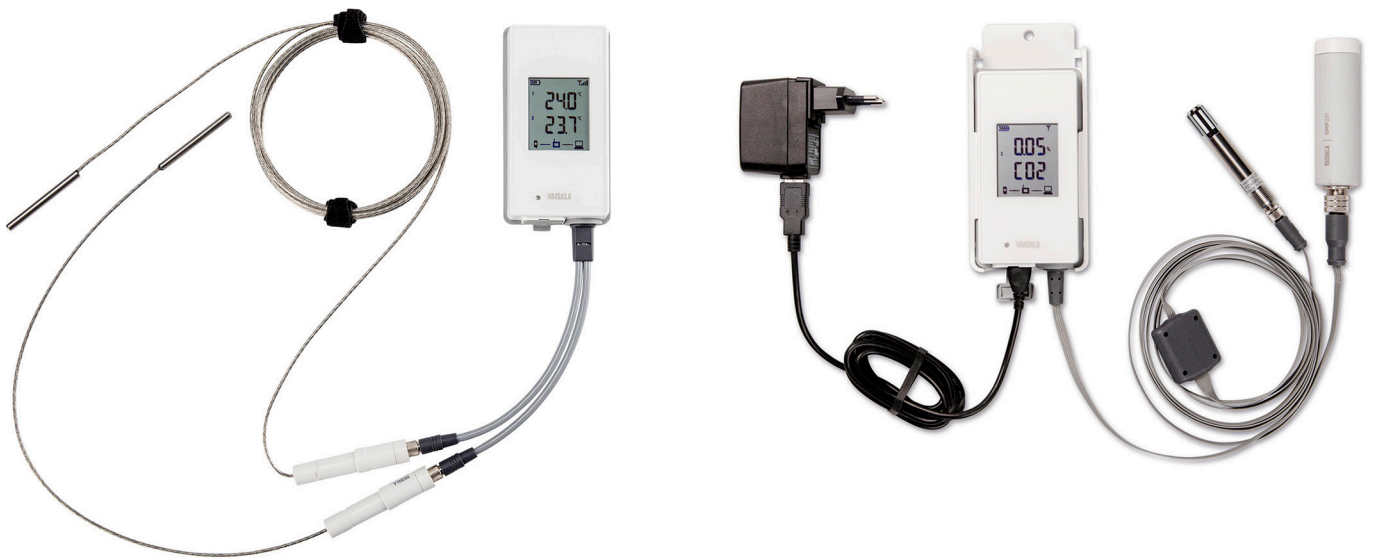

RFL100 with two TMP115 probes (left) and with GMP251 and HMP110 probes (right)

Technical data

Wireless

Networking standards	Vaisala VaiNet
Modulation	Chirp spread spectrum modulation
Output power	≤ 13 dBm (≤ 20 mW)
Antenna	Internal
Typical range (indoors)	At least 100 m (approx. 330 ft)
Range with line-of-sight	Over 500 m (1640 ft)
Frequency bands	500 MHz, 868 MHz, 915 MHz, 920 MHz, and 922 MHz

Memory

Sample capacity	30 days (43200 samples per channel)
Memory type	Non-volatile EEPROM
Memory mode	Ring buffer (FIFO)
Sampling rate	One sample / channel / minute (non-changeable)

General

Compatible probes	GMP251, HMP110, HMP110T, HMP115, HMP115T, TMP115
Batteries	2 × AA sized, 1.5 V (LR6 or FR6)
Operation time on battery power at 20 °C (68 °F)	
RH and T measurement in any probe combination	18 months
CO ₂ measurement	Typically 12 hours with lithium batteries

Compatibility requirements

Item	Required minimum version(s)
viewLinc version	viewLinc Enterprise Server 5.0
Dual T probe support using Probe Splitter M8 accessory	<ul style="list-style-type: none">RFL100 firmware 1.2.0AP10 firmware 3.0viewLinc Enterprise Server 5.0.2
CO ₂ measurement using Probe Splitter M8/M12 accessory and external power	<ul style="list-style-type: none">RFL100 firmware 1.4.0RFL100 hardware manufactured after July 2021AP10 firmware 4.0 and hardware revision GviewLinc Enterprise Server 5.1

Operating environment

Storage temperature	-40 ... +60 °C (-40 ... +140 °F)
Operating humidity	0 ... 100 %RH, non-condensing
IP rating	IP54
IP rating with external power supply	IP20
Operating temperature ¹⁾	
with alkaline batteries	+2 ... +60 °C (+35.6 ... +140 °F)
with lithium batteries	-20 ... +60 °C (-4 ... +140 °F)
with external power supply	0 ... +60 °C (+32 ... +140 °F)

¹⁾ Verify operating temperature specification when using third party batteries and power supplies.

Compliance

EMC compatibility	IEC/EN 61326-1, industrial environment
Electrical safety	IEC/EN 61010-1
500 MHz model	
Radio standards and approvals	China MIIT 工业和信息化部公告 2019 年第 52 号
Compliance marks	China RoHS
868 MHz model	
EU directives and regulations	RoHS Directive (2011/65/EU) amended by 2015/863 Radio Equipment Directive, RED (2014/53/EU)
Radio standards and approvals	ETSI EN 300 220-2 ETSI EN 301 489-1 ICASA No: TA 2020-7761 IMDA No: DB105576 TRA No: 67584/18 Serbia: M005 21
Compliance marks	AAA, CE, ICASA, UKCA
915 MHz model	
Radio standards and approvals	Anatel ID: 04761-19-12322 AS/NZS 4268 FCC ID: 2A039-RFL100A IC ID: 23830-RFL100A NOM ID: 1901C00493
Compliance marks	ANATEL, NOM, NYCE, RCM
920 MHz model	
Radio standards and approvals	MIC ID: 012-200007
Compliance marks	GITEKI
922 MHz model	
Radio standards and approvals	NCC ID: CCAP21LP1240T3
Compliance marks	NCC

Mechanical specifications

Housing color	White
Mounting methods	Screws, cable ties, hook, or magnetic mounting bracket (optional accessory)
Probe interface	4-pin female M8 connector
Service port	USB 2.0 with micro-USB connector

Dimensions (H × W × D) with HMP115 probe

Without mounting bracket	158 × 62 × 31 mm (6.22 × 2.4 × 1.22 in)
With mounting bracket	186 × 68 × 36.5 mm (7.32 × 2.68 × 1.44 in)

Weight

With batteries (2 pcs alkaline) and HMP115 probe	190 g (6.7 oz)
With batteries (2 pcs alkaline), HMP115 probe, and magnetic mounting bracket	254 g (8.96 oz)

Materials

Housing	PC/ABS blend
Display window	PMMA (acrylic)
Sealings	TPE

Requirements for external power supply

Output voltage	5 V DC
Output power	Min. 1 W
Output connector	Micro-USB
Certifications and approvals	<ul style="list-style-type: none">• Certified to IEC 62368-1• Approved for use in your country

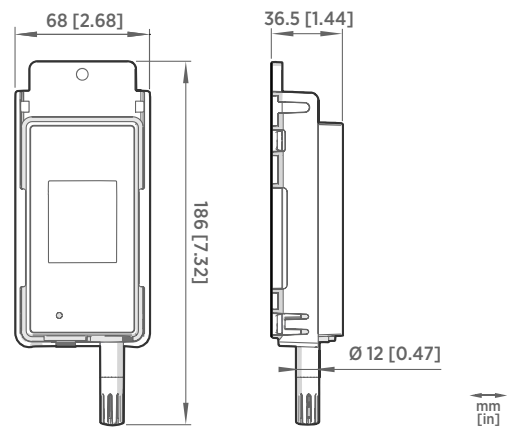

RFL100 dimensions with HMP115 probe